



E-Tech®

by Franklin Electric

DriveE-Tech series



015	040
018M	055
022	075
025M	110
030	150

DriveE-Tech



VFD

**Variable
Frequency
Drive**

Applications



Industrial applications

Building service



Commercial



Irrigation

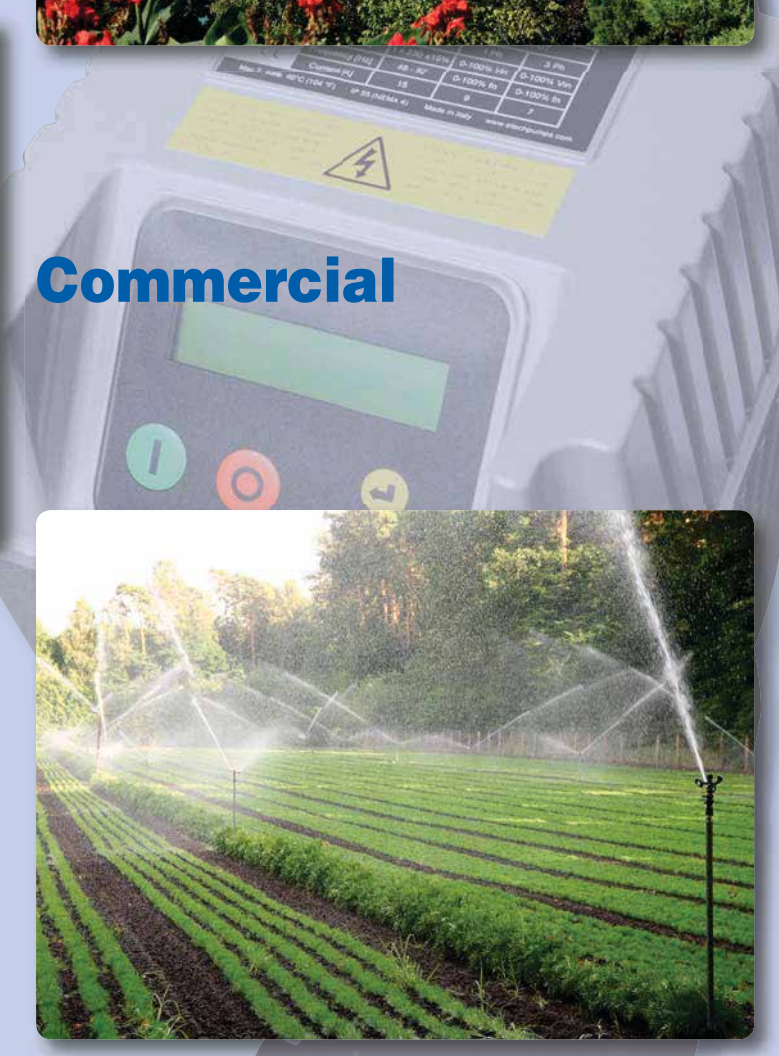

Model	Flow Rate	Pressure	Temperature	Accuracy
1000	10 GPM	100 PSI	50°F	±1%
1000	10 GPM	100 PSI	50°F	±1%
1000	10 GPM	100 PSI	50°F	±1%
1000	10 GPM	100 PSI	50°F	±1%

DrivE-Tech - A new generation of VFD

DrivE-Tech

The new line of VFD DrivE-Tech has been designed and developed to optimize, control and protect pumping systems built with different kind of pumps like vertical multistage, centrifugal and submersible.

DrivE-Tech can work in applications like domestic, water supply, irrigation, commercial, HVAC, washing and more – it is suitable to operate in most of new or existing systems.

The installation of a DrivE-Tech allows the user to gain important benefits like:

- Reduced energy consumption with remarkable cost saving
- Longer life of pumping system
- Greater reliability of the complete unit

DrivE-Tech controls are uniquely compact, and plugged with most of the pumps available in the market they can ensure steady operation conditions in terms of pressure, flow and temperature.

DrivE-Tech delivers motor protection and monitoring, such as:

- overload and dry running protection
- integrated soft start and soft stop functions, extending the life of the system and reducing peak variation
- input current and supply voltage
- recording running hours and login errors and alarms reported by the system
- controlling a second or third pump at constant speed DOL (DOL: Direct On Line)
- connecting to other DrivE-Tech to get combined operation

DrivE-Tech enclosure is entirely made of die-cast aluminum and is very sturdy, lightweight, easy to cool down and very compact in size.

Protection degree of the panel is IP55 thus it can be installed in humid and dusty places.

A display placed on top of DrivE-Tech and a buzzer in case of alarm help to operate the VFD in the most efficient and easy conditions.



Installation tips and set up of DrivE-Tech

DrivE-Tech is designed to be installed on top of motor fan cover or fixed to a wall with its dedicated kit

Motor kit

DrivE-Tech can be placed on top of pump motor with 4 customized clamps supplied with all type of VFD.

In this type of installation the DrivE-Tech is cooled by the fan of motor.



Wall kit*

DrivE-Tech can be fixed to a wall with a customized support supplied as option.

The cooling of the VFD is guarantee by an external fan attached to the radiator.

* Not available for DrivE-Tech 150



Wiring of DrivE-Tech

1. Connect the DrivE-Tech to the pump's motor.
2. Connect the DrivE-Tech to power supply.
3. Connect the DrivE-Tech to the pressure sensor supplied with the inverter.

Configuration of DrivE-Tech

Thanks to its friendly user software DrivE-Tech is easy to set up, the synoptic panel gives a step by step guide through the various parameters that have to be entered or modified.

DrivE-Tech can operate with multiple combinations:

- 1 DrivE-Tech with one pump plus 1 or 2 more pumps directly conneted to power supply.
- From 1 up to 8 pumps in parallel and each one wired to a DrivE-Tech. This installation optimize the efficiency and reliability of the system.
- From 1 up to 8 DrivE-Tech with same number of pumps plus additional 1 or 2 pumps DOL connected.

First case



Second case



Third case



Easy configuration software

When first powering the DrivE-Tech, an initial configuration is required for the complete setup of the drive.

Additional parameters can be configured later by entering three different setting levels:

- **End user level.** The only level which can be accessed without password. It allows the user to monitor electrical and hydraulic parameters and status of the DrivE-Tech and pump.
- **Installer level.** In this level, the installer can configure the DrivE-Tech - pump system to the characteristics of the hydraulic system. An entry password is required.
- **Advanced level.** This level allows the electrical configuration of DrivE-Tech to the pump. Another entry password is required.



Constant pressure control

DrivE-Tech controls the pump speed to maintain constant pressure at a set point, independently of the water demand in the system.

In an hydraulic system equipped with DrivE-Tech, the standard pressure tank is replaced by a smaller tank which functions to maintain the set pressure in the system when the pump is stopped.

In traditional systems with fixed speed pumps, the larger size of the pressure tank is due to the number of pump starts and to the maximum flow rate of the pump.

In large tanks, special precaution have to be taken if the working pressure is high or if there is a possibility of extended stagnation of the water causing bacteria.

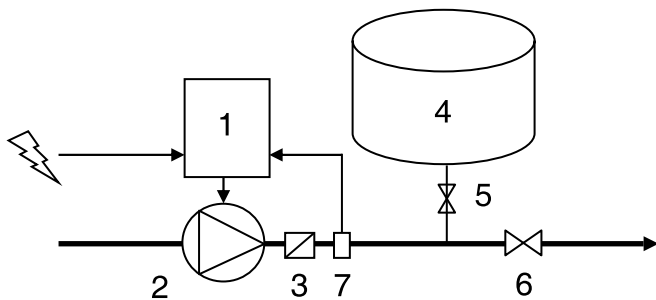

- | | |
|--------------------|------------------------|
| 1. DrivE-Tech | 4. Pressure tank |
| 2. Pump | 5. Valve |
| 3. No return valve | 6. Valve |
| | 7. Pressure transducer |

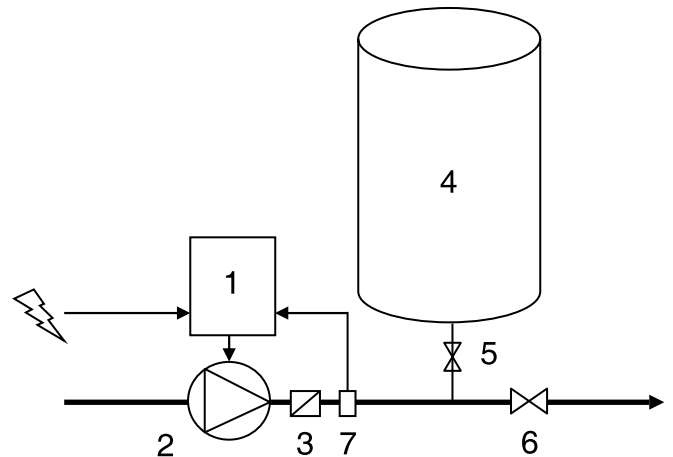

- | | |
|--------------------|--------------------|
| 1. Control Box | 5. Valve |
| 2. Pump | 6. Valve |
| 3. No return valve | 7. Pressure switch |
| 4. Pressure tank | |

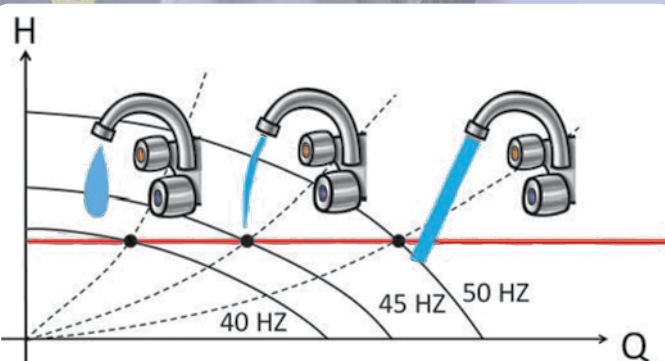

DrivE-Tech receives a pressure signal from the pressure transducer and change pump speed to keep a constant set pressure regardless of water demand.

Electronic tailored for pumps

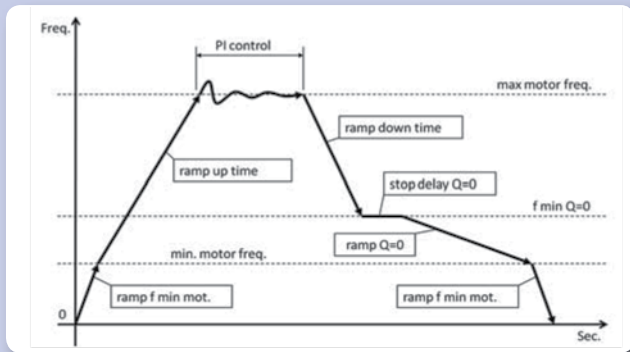

Minimum motor frequency

This parameter prevents the pump from running lower below a certain speed, avoiding the risk of damaging the thrust bearing in submersible pumps.

Minimum motor frequency ramp

To prevent motor damage, the motor can accelerate quickly to reach the minimum motor frequency, and then is allowed to follow a lower start-up ramp.

Stop function at zero water flow

After reaching the minimum frequency at zero flow ($F_{min} Q=0$) DrivE-Tech progressively slows the pump while monitoring the signal from the pressure transducer. If the pressure is close to the set pressure, DrivE-Tech stops the pump.

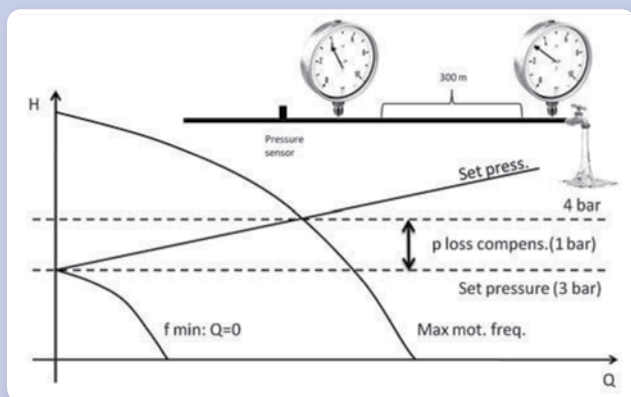
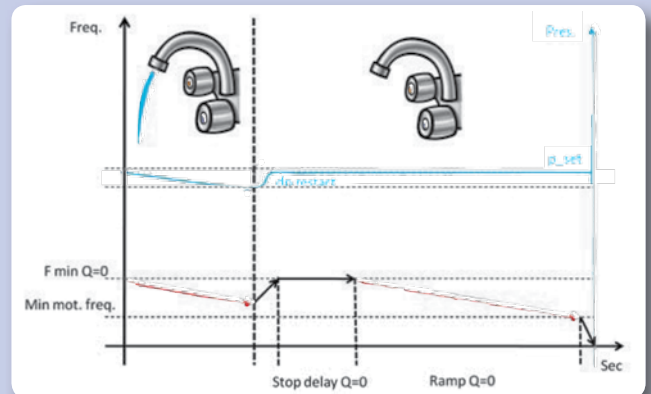

Loss compensation proportional to the water flow

If the pressure sensor is placed near the pump, pressure value on the working point is lower than set pressure due to the loss proportional to the water flow.

It is possible to vary the pressure set in a linear relation with respect to the frequency to compensate pressure loss in the pipes.

Dry running signal via $\cos \phi$ value

If pump runs dry, its $\cos \phi$ value drops below a settable $\cos \phi$ value and DrivE-Tech stops the pump after 2 seconds. DrivE-Tech will try to start the pump every 10,20,40,80 and 160 minutes, after which it will declare an alarm and stop the pump if the condition persists.

Maximum and minimum pressure alarm

When the pressure rises above a certain settable pressure value, DrivE-Tech will stop the pump to prevent damages to the hydraulic components in the system.

Similarly, if the pressure drops below a certain set pressure an alarm is declared and the pump is stopped.

V/f programmable curve

DrivE-Tech allows to choose between two different methods of torque control voltage versus pumps speed (frequency):

- constant torque (linear V/f)
- quadratic variable torque (squared V/f)

For centrifugal pump, energy savings can be obtained by selecting squared V/f control.

Settable carrier frequency between 2.5, 4, 8, 10, 12 kHz

If DrivE-Tech controls a submersible pump with long cables, it is possible to decrease the carrier frequency value to ensure longer motor life.

Several control modes available

In addition to constant pressure control, DrivE-Tech allows other control modes such as fixed frequency, constant flow, constant temperature.

Performance chart

Model	V _{in} ±15% [V]	max V _{out} [V]	I _{out} [A]	Typical motor P2 [kW]
DrivE-Tech 015	1 x 230	1 x 230	9	1.1 KW
	1 x 230	3 x 230	7	1.5 KW
DrivE-Tech 018M	1 x 230	3 x 230	18	4 KW
DrivE-Tech 022	3 x 400	3 x 400	6	2.2 KW
DrivE-Tech 025M	1 x 230	3 x 230	25	5.5 KW
DrivE-Tech 030	1 x 230	1 x 230	9	1.5 KW
	1 x 230	3 x 230	11	3 KW
DrivE-Tech 040	3 x 400	3 x 400	9	4 KW
DrivE-Tech 055	3 x 400	3 x 400	14	5.5 KW
DrivE-Tech 075	3 x 400	3 x 400	18	7.5 KW
DrivE-Tech 110	3 x 400	3 x 400	25	11 KW
DrivE-Tech 150	3 x 400	3 x 400	30	15 KW

DrivE-Tech 015-018M-022-025M-030-040

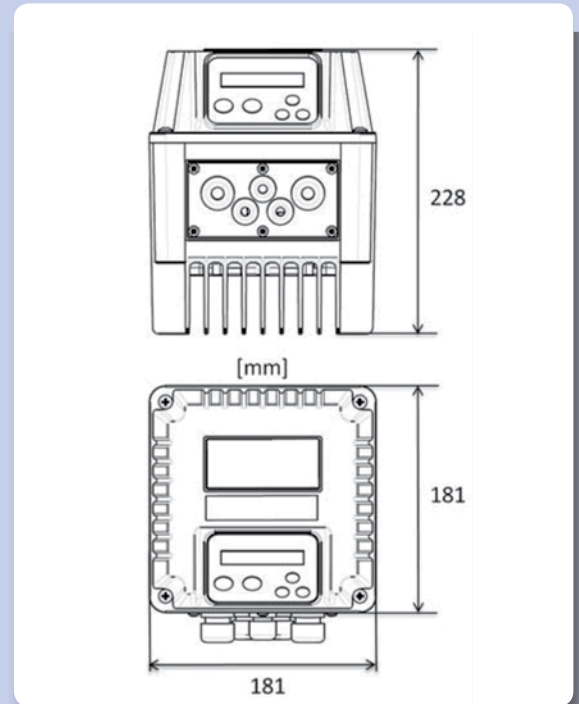

Technical features

- Power frequency: 50 - 60 Hz (±2%)
- Max. ambient temperature at nominal current: 40°C (104 °F)
- Max. altitude at nominal current: 1000 m
- Grade of protection: IP55 (NEMA 4)
- Settable digital output signals (N.O or N.C):
 1. Motor run signal
 2. Alarm signal
 3. DOL 1 pump signal
 4. DOL 2 pump signal
- Analog input (10 or 15 Vdc):
 1. 4-20 mA
 2. 4-20 mA
 3. 4-20 mA / 0 - 10 Vdc (settable)
 4. 4-20 mA / 0 - 10 Vdc (settable)
- 4 Digital input, N.O. or N.C (settable), for motor run and motor stop
- RS485 serial communication

DrivE-Tech 055-075-110-150

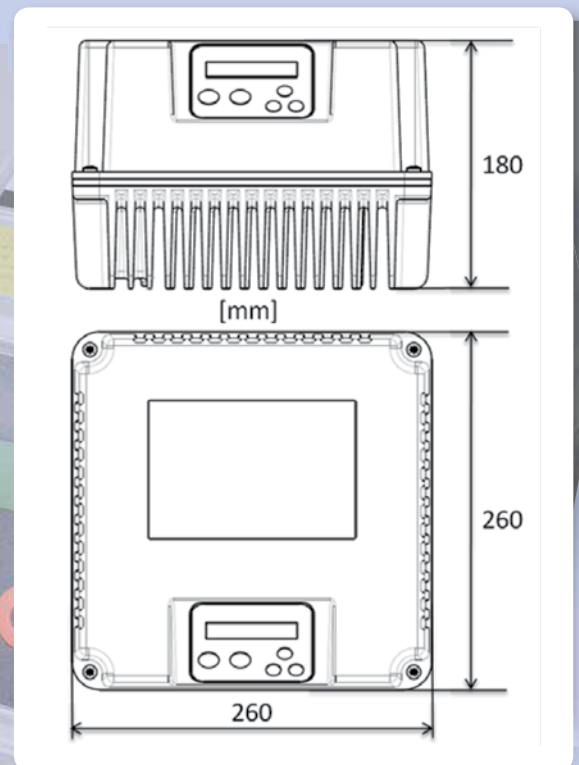

Accessories: please check your local supplier for accessories included with the DrivE-Tech.



E-Tech[®]

by Franklin Electric

Vertical S.p.A.
via Asolo, 7
36031 Dueville (Vicenza) - Italy



Franklin Electric

AUSTRALIA / NEW ZEALAND

Franklin Electric (Australia) Pty. Ltd.
106-110 Micro Circuit, Dandenong South,
Victoria 3175, Australia

Toll Free: 1300 FRANKLIN
1300 372 655

Fax: +61 3 9799 5050
Tel: +61 3 9799 5000
www.franklinwater.com.au

DrivE-Tech and E-Tech are brands of Vertical S.p.A,
a member of the Franklin Electric group of Companies