

Drive**E**-Tech solar

*Installing and
operating manual*



022
030
040
055
075
110
150

Index

1. DrivE-Tech Solar Introduction	3
2. Safety Instructions	4
3. Technical Characteristics	5
3.1 Weight and dimensions	5
4. Electric wiring	6
4.1 Protections	8
4.2 Electromagnetic compliance.....	8
4.3 Installation with long motor cables	8
5. DrivE-Tech Solar installation	9
6. PV system sizing	10
7. DrivE-Tech Solar Use and Programming	11
7.1 DrivE-Tech Solar display	11
7.2 Initial configuration	12
8.3 Initial view	13
8.4 Menu view.....	14
8.5 Installer parameters.....	14
8.6 Advanced parameters	16
8. Protections and alarms	19

1. DrivE-Tech Solar Introduction

DrivE-Tech Solar inverters come to power traditional pumping systems using photovoltaic energy.

In this way it's possible to convert old systems in renewable energy installations or to use the same AC pumps in the creation of independent, cost-saving and environmentally sustainable water systems.

DrivE-Tech Solar is able to convert DC voltage coming from photovoltaic panels into AC voltage for powering any pump driven by three phase asynchronous motor. MPPT (Maximum Power Point Tracking) maximizes, for various conditions of irradiation and temperature, the electrical power drawn from the panels so the amount of pumped water.

Pump speed is constantly adapted to available solar irradiation thus maximizing the amount of pumped water and making possible operation even in low irradiation conditions.

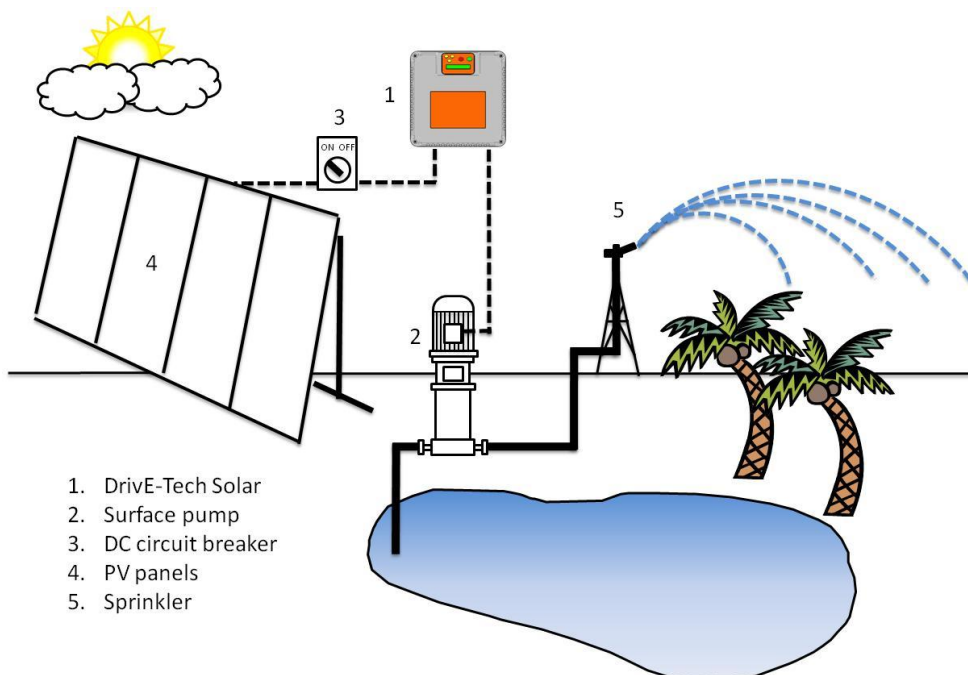
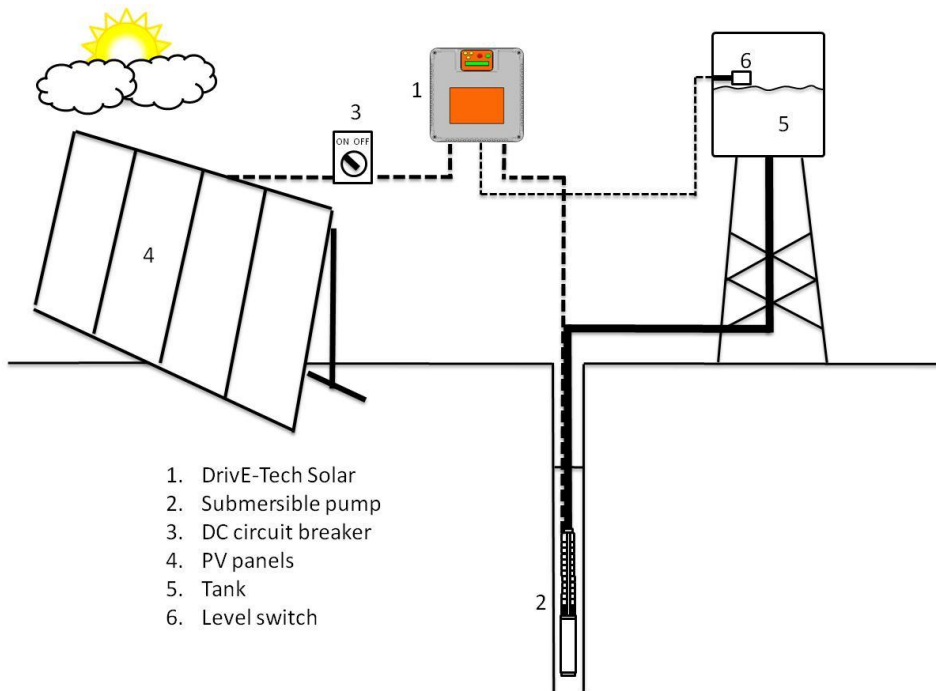

DrivE-Tech Solar also offers complete pump protection against over-voltage, over-current and dry running.

DrivE-Tech Solar can be used with any type of traditional AC pump thus offering maximum flexibility in several application areas. In the use with submersible pumps, DrivE-Tech Solar allows to fill tanks for watering livestock or simply irrigate lawns or crops. In the use with surface pumps, DrivE-Tech Solar can serve an irrigation fishing from a nearby water reserve or feed with no energy cost a pool pump.



2. Safety Instructions

The manufacturer strongly suggests carefully reading this operation manual before using and installing its products. Any operation (installation, maintenance and repair) must be carried out by trained, skilled, and qualified personnel. Failure to observe and follow the instructions in this manual may result in dangerous and potentially lethal electric shock. Pay attention to all standard safety and accident prevention regulations.

	<p>The device must be connected to main power supply via a switch to ensure the complete disconnection from the network before any operation on the DrivE-Tech Solar itself (including visual inspection) and/or on the connected load.</p>
	<p>Disconnect DrivE-Tech Solar from the power supply before commencing any work.</p> <p>Do not remove, for any reason, the cover and the cable plate without having first disconnected the device from the main power supply and having waited at least 5 minutes.</p> <p>DrivE-Tech Solar and pumping system must be grounded properly before operation.</p> <p>For the entire period DrivE-Tech Solar is powered, high voltage is present on the output terminals of the inverter whether or not the pump is running.</p> <p>Tightening all 4 screws on the cover with washers is recommended before powering the device. Otherwise, there may be a failure to connect the cover to ground, creating the risk of electric shock or even death.</p>

Avoid any shock or significant impact during transport.

Check the DrivE-Tech Solar immediately upon delivery and check for damage and/or missing parts. If either occurs, immediately notify the supplier.

Damages due to transport, incorrect installation, or improper use of the device will null and void the warranty.

Tampering or disassembly of any component will automatically void the warranty.

The manufacturer cannot be held responsible for any damages to people and/or property due to improper use of its products.

3. Technical Characteristics

Model	Vin	Vin P1 nom*	Max Vout	Max I out	Typical motor P2	
	[VDC]	[VDC]	[VAC]	[A]	[VAC]	[kW]
DrivE-Tech Solar 022	120 – 650	> 320	3 x 230	12	3 x 230	2,2
DrivE-Tech Solar 030	320 – 850	> 560	3 x 400	9	3 x 400	3
DrivE-Tech Solar 040	320 – 850	> 560	3 x 400	12	3 x 400	4
DrivE-Tech Solar 055	320 – 850	> 560	3 x 400	15	3 x 400	5,5
DrivE-Tech Solar 075	320 – 850	> 560	3 x 400	18	3 x 400	7,5
DrivE-Tech Solar 110	320 – 850	> 560	3 x 400	25	3 x 400	11
DrivE-Tech Solar 150	320 – 850	> 560	3 x 400	30	3 x 400	15

- Max ambient temperature at nominal current: 50°C (122 °F)
- Max. altitude at nominal current: 1000 m
- Grade of protection: IP65 (NEMA 4)*
- RS485 serial communication
- PWM configurable: 2.5 ,4, 6, 8, 10 kHz

* avoid direct exposition to solar rays.

DrivE-Tech Solar is able to power the motor with a higher current for a short period of time according to the linear relation: 101% of the nominal current for 10min., 110% nominal current for 1 min.

3.1 Weight and dimensions

Model	Weight *
	[Kg]
DrivE-Tech Solar 022	8,2
DrivE-Tech Solar 030	8,3
DrivE-Tech Solar 040	8,5
DrivE-Tech Solar 055	8,5
DrivE-Tech Solar 075	8,7
DrivE-Tech Solar 110	8,7
DrivE-Tech Solar 150	8,7

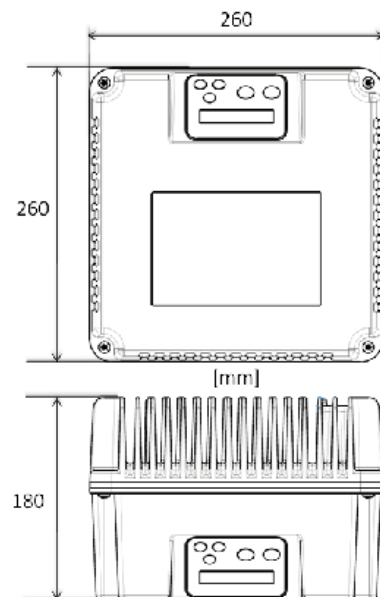

* Weight without packing.

4. Electric wiring

Power board

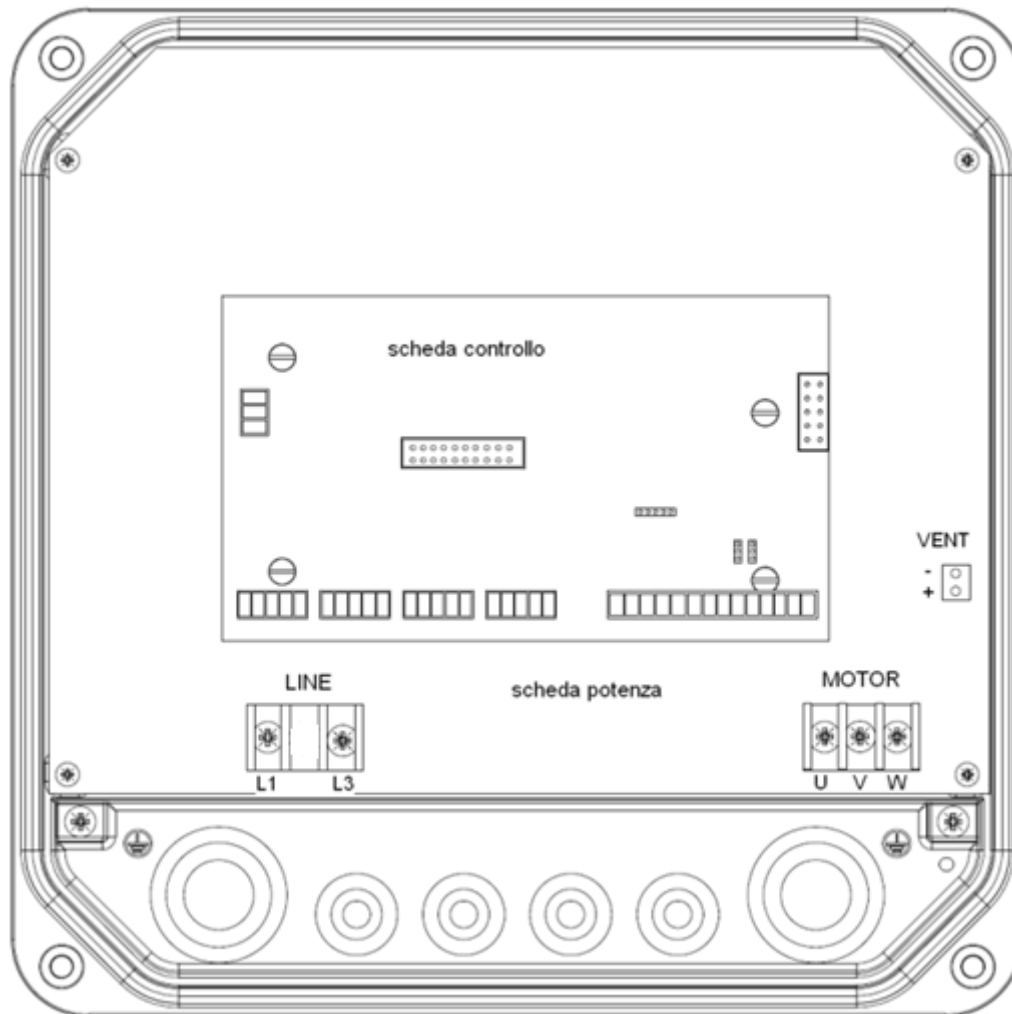

<p>DC Input:</p> <p>LINE: L1, L3, GND</p> <p>It is recommended to use cable lugs.</p> <p>It is not necessary to respect polarity.</p>	<p>Motor output:</p> <p>MOTOR: U, V, W, GND</p> <p>It is recommended to use cable lugs.</p>	<p>12 V dc auxiliary fans (wall mounting kit)</p> <p>VENT: +, -</p> <p>WARNING: respect the polarity.</p>
--	--	---

Cable stripping recommended for line input and output to the motor.

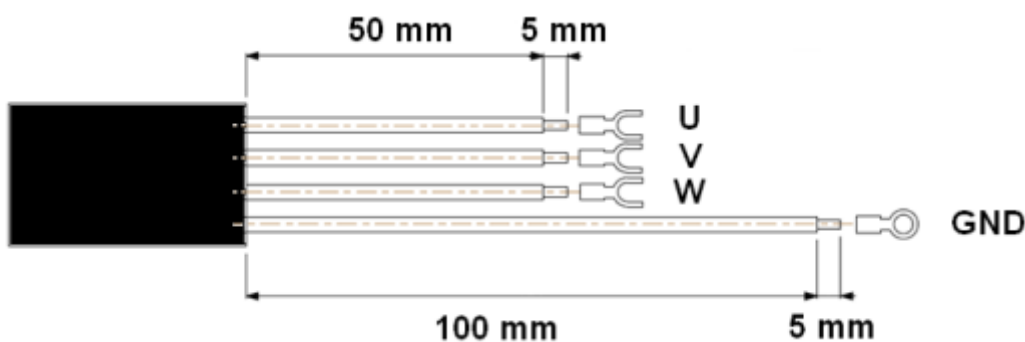

Control board

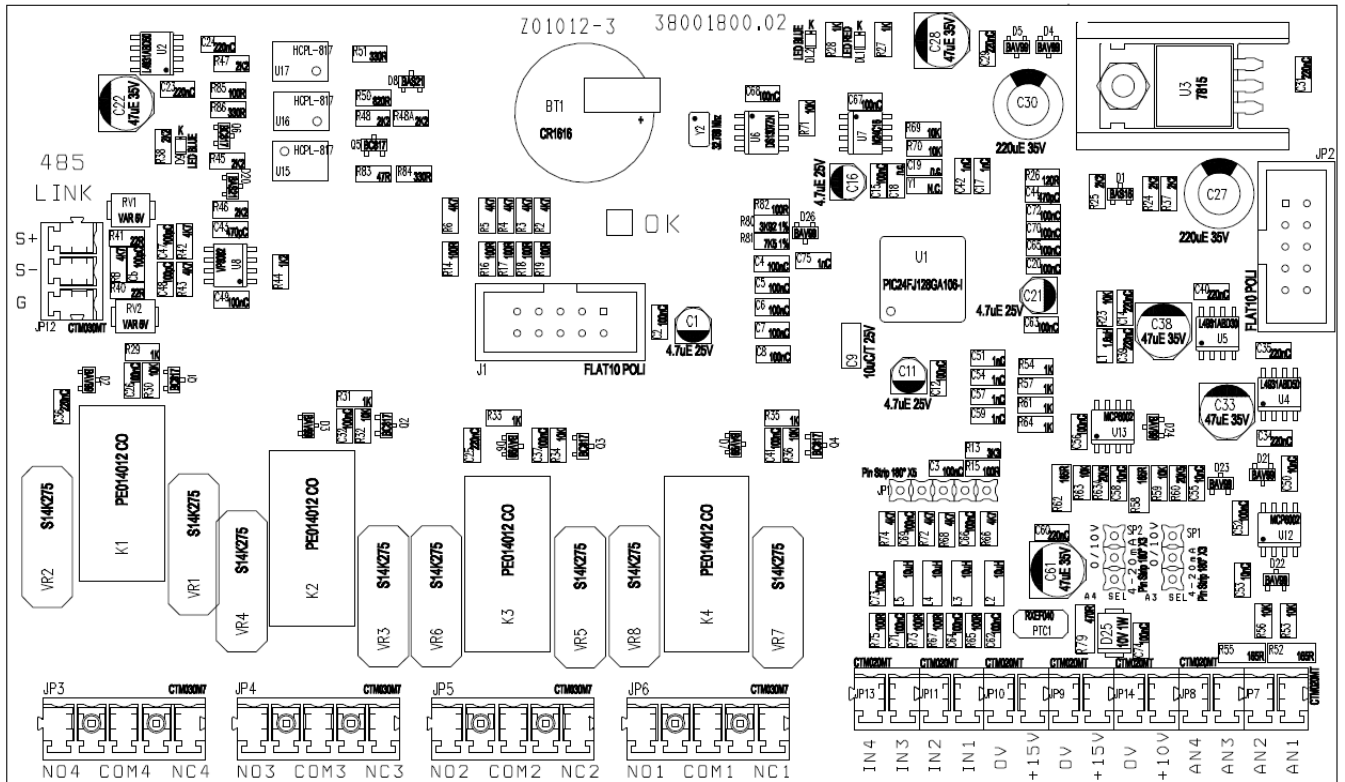

<p>Analog inputs (10 or 15 Vdc):</p> <ol style="list-style-type: none"> 1. AN1: 4-20 mA: sensor 1 2. AN2: 4-20 mA: sensor 2 3. AN3: 4-20 mA / 0 - 10 Vdc (settable by jumper C.C.): external set 4. AN4: 4-20 mA / 0 - 10 Vdc (settable by C.C.): trimmer for frequency regulation / external set 2 	<p>Digital outputs:</p> <ul style="list-style-type: none"> • motor run signal: NO1, COM1: closed contact with motor running. NC1, COM1: closed contact with motor stopped. • alarm signal NO2, COM2: opened contact without alarm. NC2, COM2: closed contact without alarm. • DOL1 pump relay: NO3, COM3: closed contact with DOL1 running. NC3, COM3: opened contact with DOL1 running. • DOL2 pump relay: NO4, COM4: closed contact with DOL2 running. NC4, COM4: opened contact with DOL2 running. <p>Relays are no voltage contacts. Max. voltage to the contacts is 250 V with max current of 5 A.</p>	<p>RS485:</p> <ul style="list-style-type: none"> • S+ • S- • G <p>It is recommended to respect the polarity linking more DrivE-Tech Solars in series.</p>
<p>Digital inputs:</p> <ul style="list-style-type: none"> • IN1 : motor start & stop • IN2: value set 1 & 2 switching • IN3: sensor 1 & 2 switching • IN4 : motor start & stop + alarms reset • 0V <p>We recommend using only no voltage contacts. Opening or closing the digital contacts (depending on software configuration set (see inst. parameters) you can start or stop the motor.</p>		

4.1 Protections

The protections required upstream each DrivE-Tech Solar depends on the type of installation, and local regulations. We recommend to use 1000 VDC circuit breaker and, if possible, 1000 VDC surge protection.

4.2 Electromagnetic compliance

To ensure electromagnetic compatibility (EMC) of the system, it is necessary to apply the following measures:

- Always connect the device to ground
- Use shielded signal cables by placing the screen at one end.
- Use motor cable as short as possible (<1 m / <3 ft). For longer lengths, it is recommended to use shielded cables connecting the screen at both ends.
- Separate signal, motor, and power supply cables.

Note: To enable the restoration of the display screen when there are electromagnetic interference, DrivE-Tech Solar periodically provides some fast "refresh" of the display.

4.3 Installation with long motor cables

With long motor cables it's recommended to decrease the commutation frequency from 10 kHz (default) to 2.5 kHz (advanced parameters). This reduces the probability of voltage spikes in the motor windings which may damage the insulation.

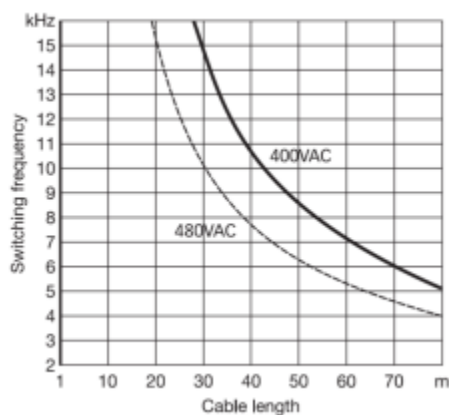

To prevent dangerous overheating of dv / dt and sinusoidal filters it is recommended to set the correct PWM value in relation to the cable length.

For motor cable lengths up to 50 meters it's recommended to place between DrivE-Tech Solar and motor a dv / dt reactance, available on request.



For motor cable lengths greater than 50 meters it's recommended to place between DrivE-Tech Solar and motor a sinusoidal filter, available on request.



5. DrivE-Tech Solar installation

- n.° 2 12 V DC fans.
- n.° 1 fans cover.
- n.° 2 fans cover fixing screws
- n.° 2 wall fixing brackets
- n.° 4 M5 screws for DrivE-Tech Solar fixing to the brackets
- n.°1 holes reference sheet

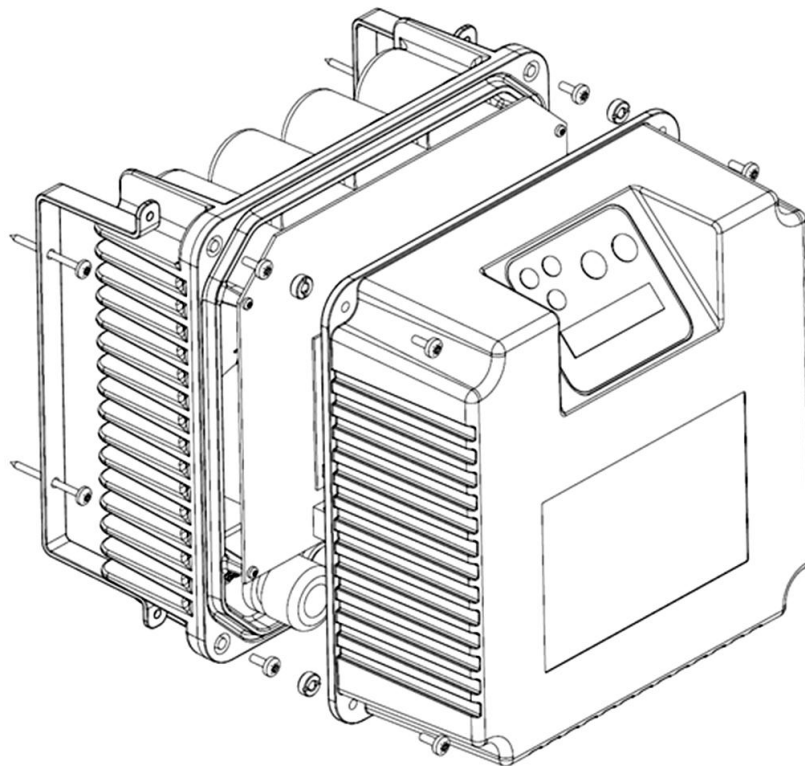
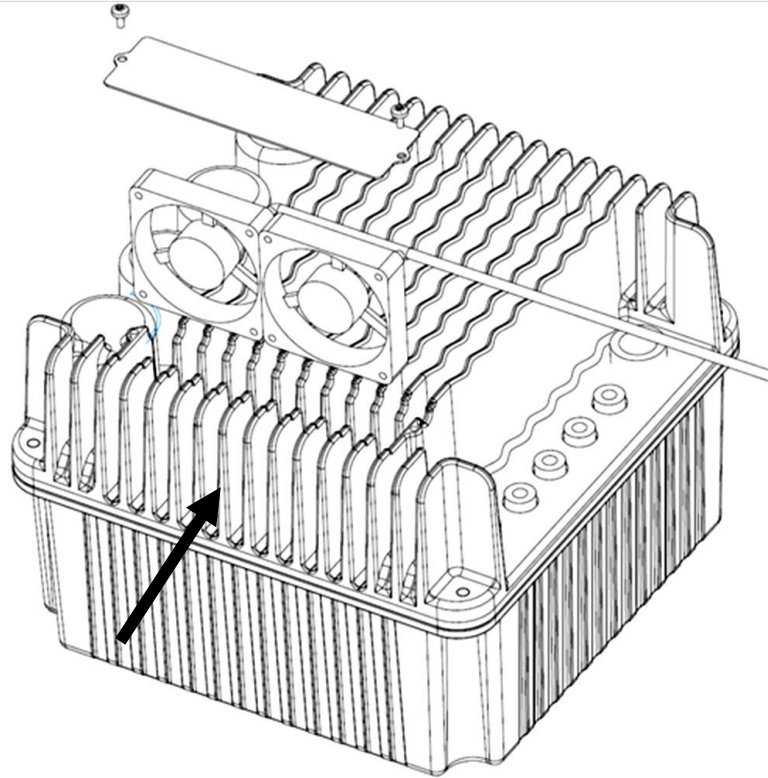

6. PV system sizing

The pumping system must be designed considering daily flow rate required, total head and installation site. In particular, the choice of the pump must be carried out considering the average daily radiation.

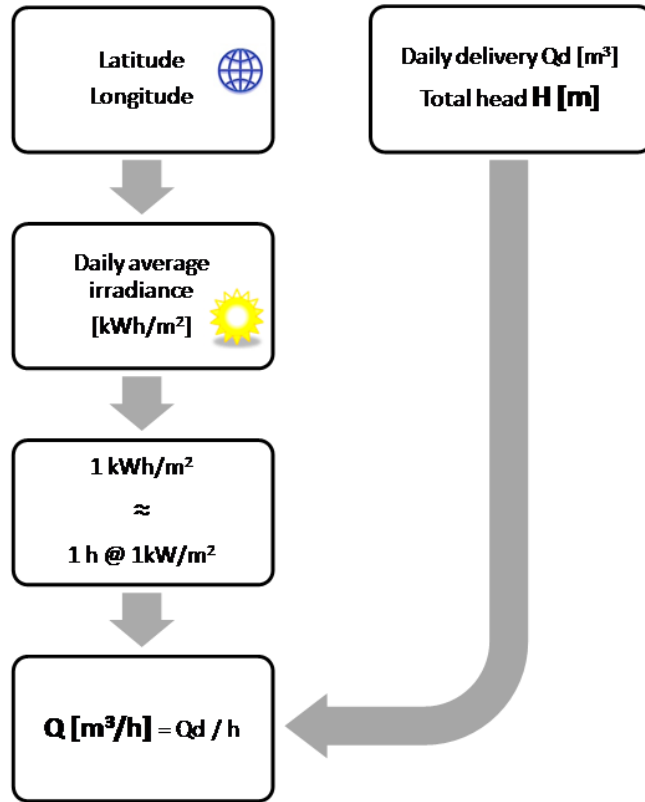

Once determined the required pump, must need to know:

- Rated pump power (P2)
- Electrical motor power (P1). P1 can be derived by dividing P2 with motor efficiency.
- Rated motor current
- Rated motor voltage (3 x 230 VAC or 3 x 400 VAC)

DrivE-Tech Solar model to be used is determined by considering voltage and rated motor current.

To ensure maximum performance, the PV system, consisting of 1 or more strings of solar panels connected in series, must provide:

- Electrical motor power (P1)

The photovoltaic power (Wp) must be at least equal to the electric motor power (P1). Typically, taking into account the efficiency loss due to panels temperature, it is recommended to increase Wp of 15% respect to P1.

- Rated motor voltage at maximum power

The rated voltage of each PV string (Vmp) must be at least equal to the rated motor voltage multiplied by the factor 1,4.

- The open-circuit voltage of each string (Voc) must be less than the maximum operating voltage of DrivE-Tech Solar.

Example:

Pump nameplate

- Rated motor power: P2 = 3 kW
- Electric motor power: P1 = 4 kW
- Rated motor current: 8.3 A
- Rated motor voltage: 3 x 400 VAC

DrivE-Tech Solar selection

Being the rated motor voltage 400 VAC and the rated current 8.3 A, the most suitable model for the application is DrivE-Tech Solar 409.

PV system sizing

PV panels used:

- $W_p = 240 \text{ W}$
- $V_{mp} = 30 \text{ VDC}$
- $V_{oc} = 37 \text{ VDC}$
- $I_{mp} = 8 \text{ A}$

Since $P_1 = 4 \text{ kW}$, considering efficiency loss due to temperature, the required electrical power is increased of 15% so $W_p = 4.6 \text{ kW}$.

To develop 4.6 kW are needed 19 panels of 240 W.

$V_{mp} = 19 \times 30 = 570 \text{ VDC}$ is greater than the rated motor voltage multiplied by 1.4 ($400 \times 1.4 = 560 \text{ VDC}$) and $V_{oc} = 19 \times 37 = 703 \text{ VDC}$ is less than the maximum voltage of DrivE-Tech Solar 409 (850 VDC).

For this reason a single string of 19 PV panels can be installed.

7. DrivE-Tech Solar Use and Programming

DrivE-Tech Solar software is extremely simple to use, but allows a wide variety of parameters to be set for ideal system calibration. Setting Parameters are organized in 2 levels:

1: Installer level

A password is required for this level; these parameters are adjustable by trained professionals

Default password: **001**

From the menu a different password can be set up.

2. Advanced level

A second and different password is required; improper setting of these advanced parameters could compromise the integrity and the life of DrivE-Tech Solar and pump;

Default password **002**

It is possible to set up a different password.

Installer and Advanced levels can be entered only with the correct password; otherwise, it is impossible to set up and/or modify any parameters (they can be only displayed).

7.1 DrivE-Tech Solar display

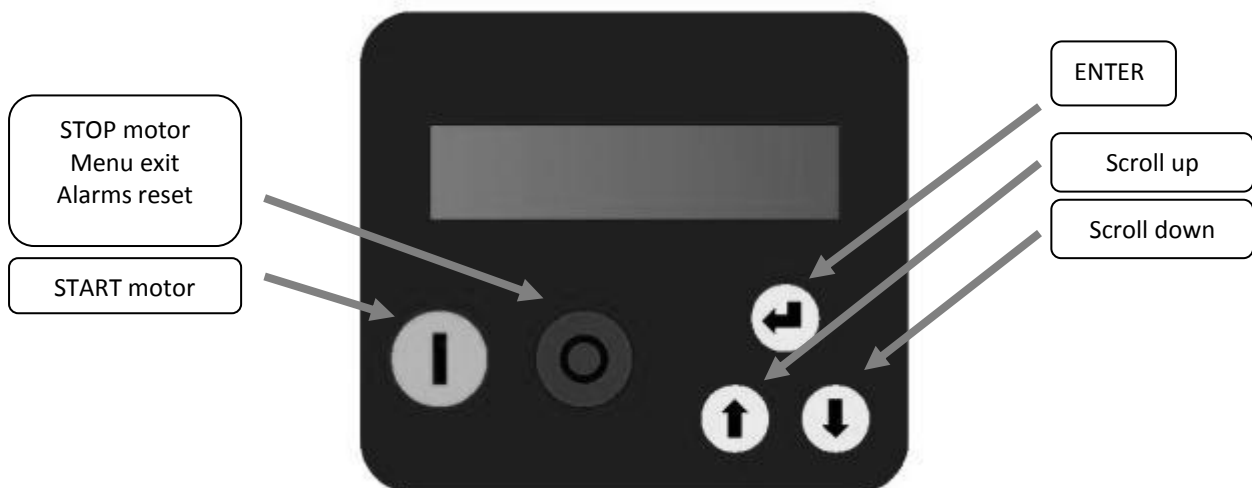

Screen is a back-lit LCD displaying 2 rows of 16 digits each. Alarms are indicated by an audible signal.

7.2 Initial configuration

When Drive-Tech Solar is switched on for the first time, the initial setting menu is displayed for the initial setting of parameters to configure pump and system characteristics.

If the initial setting procedure is not completed properly, it is impossible to run the pump. Initial setting procedure can be repeated if necessary.

The initial setting procedure can be repeated (by using the 2nd level password) to reconfigure Drive-Tech Solar or if Drive-Tech Solar is installed in a different system.

A brief description of parameters and their allowable ranges are listed below:

Parameter	Default	Description
Language XXXXXX	XXXX	End user communication language
Open circuit Volt. PV V = XXX [V]	XXX	Open circuit voltage of PV strings. Please refer to PV panels datasheet.
Rated motor Volt. V = XXX [V]	XXX	Motor rated voltage (as shown in the motor plate) Average voltage drop due to the inverter is between 20 V and 30 Vrms based on load condition.
Rated motor Amp. I = XX.X [A]	XX	Rated current of the motor per its nameplate indication increased by 10%. The voltage drop caused by the inverter leads to higher input current than nominal. Make sure motor is capable of accepting increased current.
Rated motor freq f = XXX [Hz]	50	Rated frequency of the motor per its nameplate.
Control mode: MPPT		
Motor test START/STOP		Press START/STOP to run a test at rated frequency Warning: make sure to run the system without damaging pump and system
Rotation sense ---> / <---	--->	If, during the test, the motor runs in reverse, it is possible to change the wiring sequence via software without physically changing wires at the terminals.
Autorestart ON/OFF	OFF	If ON is selected, after a lack of voltage, Drive-Tech Solar returns to its normal status; if Drive-Tech Solar was powering the pump before the voltage drop, it resumes powering the pump automatically. <u>Warning</u> , review the advice in chapter 1
INITIAL SETUP COMPLETED		Once the Setting procedure is completed you will get this indication on the display; setting parameters are recorded by Drive-Tech Solar; these parameters can be set up individually in the INSTALLER Parameters menu or ADVANCED Parameters menu.

8.3 Initial view

When first powering the DrivE-Tech Solar, the display shows : release of display software (LCD = X.XX) and the release of inverter software (INV = X.XX) as shown below:

LCD = X.XX
INV = X.XX

The following End User messages are displayed by pushing the scroll buttons:

Inv: ON/OFF Mot: ON/OFF p = XX.X [bar]	<p><i>p</i> is the pressure value read by the pressure transducer. By pressing ENTER the pressure set value is displayed <XXX.X></p>
Inv: ON/OFF Mot: ON/OFF V_in = XXX [Hz]	<p>V_in is the line voltage.</p>
Inv: ON/OFF Mot: ON/OFF I= XX.X [A]	<p>I is the the absorbed motor current.</p>
Inv: ON/OFF Mot: ON/OFF cosphi = XXX	<p>cosphi index means the angle phi between the voltage and current absorbed by the motor</p>
Inv: ON/OFF Mot: ON/OFF P = XXXXX [W]	<p>P is the power in Watts supplied to the pump.</p>
Inv: ON/OFF Mot: ON/OFF STATUS: NORMAL Inverter Life xxxxx h : xx m Motor Life xxxxx h : xx m %f 25 50 75 100 %h XX XX XX XX XXXXXXXXXXXXXXXX XXXXXXXX h : XX m	<p>NORMAL status means no alarms. If an alarm occurs, a message blinks on the display and an audible signal is activated. Pressing ENTER accesses: DrivE-Tech Solar lifetime, PUMP lifetime, consumption statistic, alarm list. To return to previous views, press ENTER.</p>

First row gives the DrivE-Tech Solar status:

- **Inv: ON XXX.X Hz** DrivE-Tech Solar is powered and is powering the motor showing its frequency.
- **Inv: ON Mot: OFF** DrivE-Tech Solar is powered but motor is not running
- **Inv: OFF Mot: OFF** DrivE-Tech Solar is not powered

8.4 Menu view

Pressing ENTER when you are in [MENU' / ENT to access] in initial display, will display the following MENUs:

MENU' Install. param.	Installer password required to enter level 1 (default 001)
MENU' Advanced. param.	Advanced password required to enter level 2 (default 002)
MENU' Retrive init.set	Installer password required to enter level 1 (default 001) It is possible to return to original set parameters.
MENU' Change init.set.	Advanced password required to enter level 2 (default 002)

To exit the Menu level and return to initial display, press STOP button.

8.5 Installer parameters

Many of the Installer parameters are set during the Initial Configuration (*chapter 6.2 Initial Configuration*).

However, through the Installer Parameters menu, it is possible to change the set parameters or set others in order to perfect the calibration of Drive-Tech Solar to the pumping system.

parameter	default	description
<div style="border: 1px solid black; padding: 5px;"> <p>Control mode</p> <ul style="list-style-type: none"> • MPPT • Constant value • Fix speed • Const.value 2set • Fix speed 2 val. • External speed </div>	MPPT	<p>Mode of control:</p> <ul style="list-style-type: none"> • MPPT: pump speed is adjusted in order to obtain maximum power available from PV panels. • Constant value: Drive-Tech Solar changes the speed of pump to keep the set value constant, independent of water demand. • Fix speed: Drive-Tech Solar feeds the pump a set frequency, so the speed of motor is kept constant. • Const. value 2 set: the two values are selected by opening or closing the digital input IN2. • Fix speed 2 val: to be selected by opening or closing the digital input IN2. • External speed: control motor frequency by using analogical input AN4.
<div style="border: 1px solid black; padding: 5px;"> <p>Unit</p> <p>XXXXX</p> </div>	bar	Unit
<div style="border: 1px solid black; padding: 5px;"> <p>F. scale sensor</p> <p>p = XX.X [bar]</p> </div>	16	Sensor full scale.

parameter	default	description
Min value sensor $p = XX.X$ [bar]	0	Sensor minimum value.
Max alarm value $p = XX.X$ [bar]	10	Maximum value allowed in the system. If the readen value goes over this value, an alarm occurs and the pump is stopped. Pump is automatically restarted if the readen value goes below the maximum value for a period of at least 5 seconds.
Min alarm value $p = XX.X$ [bar]	0	Minimum value allowed in the system. If the readen value goes lower than this value, an alarm occurs and the pump is stopped. Pump is automatically restarted if the readen value goes higher than the minimum value for a period of at least 5 seconds.
Rotation sense ---> / <---	--->	If, during the test, the motor runs in reverse, it is possible to change the wiring sequence via software without physically changing wires at the terminals.
Dry run cosphi cosphi = X.XX	0.65	If the pump goes into dry-running, the cosphi reaches its lowest level. To set this value, contact the pump manufacturer or test by closing the suction and checking the value on the DrivE-Tech Solar display; a value can be set by assuming a dry cosphi equivalent to 60% of the rated cosphi specified by the manufacturer.
Restarts delay t = XX [min]	10	Restart delay after a dry running alarm. At each tentative (max 5) restart delay will be doubled.
Digital input 1 N.O. / N.C.	N.O.	By selecting N.A. (normally open) DrivE-Tech Solar runs the motor if the digital input 1 is open; motor will be stopped if the digital input 1 is closed. By selecting N.C. (normally closed) DrivE-Tech Solar runs the motor if the digital input 1 is closed; motor will be stopped if the digital input 1 is opened.
Digital input 2 N.O. / N.C.	N.O.	By selecting N.A. (normally open) DrivE-Tech Solar runs the motor if the digital input 2 is open; motor will be stopped if the digital input 2 is closed. By selecting N.C. (normally closed) DrivE-Tech Solar runs the motor if the digital input 2 is closed; motor will be stopped if the digital input 2 is opened.
Digital input 3 N.O. / N.C.	N.O.	By selecting N.A. (normally open) DrivE-Tech Solar runs the motor if the digital input 3 is open; motor will be stopped if the digital input 3 is closed. By selecting N.C. (normally closed) DrivE-Tech Solar runs the motor if the digital input 3 is closed; motor will be stopped if the digital input 3 is opened.
Digital input 4 N.O. / N.C.	N.O.	By selecting N.A. (normally open) DrivE-Tech Solar runs the motor if the digital input 4 is open; motor will be stopped if the digital input 4 is closed. By selecting N.C. (normally closed) DrivE-Tech Solar runs the motor if the digital input 4 is closed; motor will be stopped if the digital input 4 is opened.
Dig.In.2/3 delay t= XX [s]	3	Digital input IN2 and IN3 delay. Digital input IN1 and IN4 have 1 second fix delay.

parameter	default	description
Change PASSWORD1 ENT		Pressing ENT allows the installer level password (1st level) (default 001) to be changed.

8.6 Advanced parameters

All the advanced parameters, due to their importance, are already set during initial setup (*cap. 6.2 Initial Configuration*). However, it is always possible to modify individual parameters or modify the password 2:

Parameters	Default	Description
Open circuit Volt. PV V = XXX [V]	XXX	Open circuit voltage of PV strings. Please refer to PV panels datasheet.
Rated motor Volt. V = XXX [V]	XXX	Motor rated voltage (as shown in the motor plate) Average voltage drop due to the inverter is between 20 V and 30 Vrms based on load condition.
Voltage boost V = XX [%]	1%	Refers to the voltage increase during the start up of the motor. Warning: An excessive value can seriously damage the motor. Contact the motor manufacturer for further information. If a single-phase motor is used, a value of 1% is suggested to increase the starting torque.
Rated motor Amp. I = XX.X [A]	XX	Rated current of the motor per it's nameplate indication increased by 10%. The voltage drop caused by the inverter leads to higher input current than nominal. Make sure motor is capable of accepting increased current.
Rated motor freq f = XXX [Hz]	50	Rated frequency of the motor per its nameplate.
Max motor freq. f = XXX [Hz]	50	Maximum frequency of the motor. Note: by reducing the maximum frequency of the motor, maximum current will be reduced as well.
Min motor freq. f = XXX [Hz]	30	Minimum frequency of the motor. Note: depends on the selected pump type; for submersible pumps with water filled motors, is not advisable to set minimum frequency lower than 30 Hz in order to protect the integrity of the thrust bearings.
Ramp up time t = XX [sec]	4	Ramp-up time to reach the speed required to achieve the set pressure (or frequency value). Longer times delay the system reaching the preset value but better protect system components. Excessively long ramp-up times can create difficulties in Drive-Tech Solar setup, and can also cause false overload alarms.

<p>Ramp down time</p> <p>t = XX [sec]</p>	4	<p>Ramp-down time to reach zero speed. Longer times keep the system pressurized, while protecting the system components. Excessively long ramp-down times can create difficulties in Drive-Tech Solar setup. Excessively short ramp-down times can cause false overload alarms.</p>
<p>Ramp f min mot.</p> <p>t = XX [sec]</p>	1.5	<p>Time to reach the minimum frequency of the motor and vice versa. When Drive-Tech Solar is used to control a water filled submersible motor it's important to keep this time at 1 second.</p>
<p>PWM</p> <p>f = XX [kHz]</p>	8	<p>Carrier frequency (switching frequency). It is possible to chose PWM in the range of 2.5 ,4, 6, 8, 10 kHz . Higher values give a more sinusoidal wave with fewer losses. If long cables are used (>20 m / >76 ft) (submersible pump) it is recommended to install an inductive filter between Drive-Tech Solar and the motor (available upon request) and to set the value of PWM to 2.5 kHz. This reduces the risk of voltage spikes, which can damage motor and cable insulation.</p>
<p>V/f lin. --> quad.</p> <p>XXX %</p>	85 %	<p>This parameter allows you to change the V / f characteristic with which Drive-Tech Solar feeds the engine. The linear characteristic corresponds to constant torque with variable speed. The quadratic characteristic is normally used with centrifugal pumps. The selection of torque characteristic should be done ensuring a smooth operation, a reduction of energy consumption and a lower level of heat and acoustic noise. When feeding singlephase motors it's suggested to set V/f as linear (0%).</p>

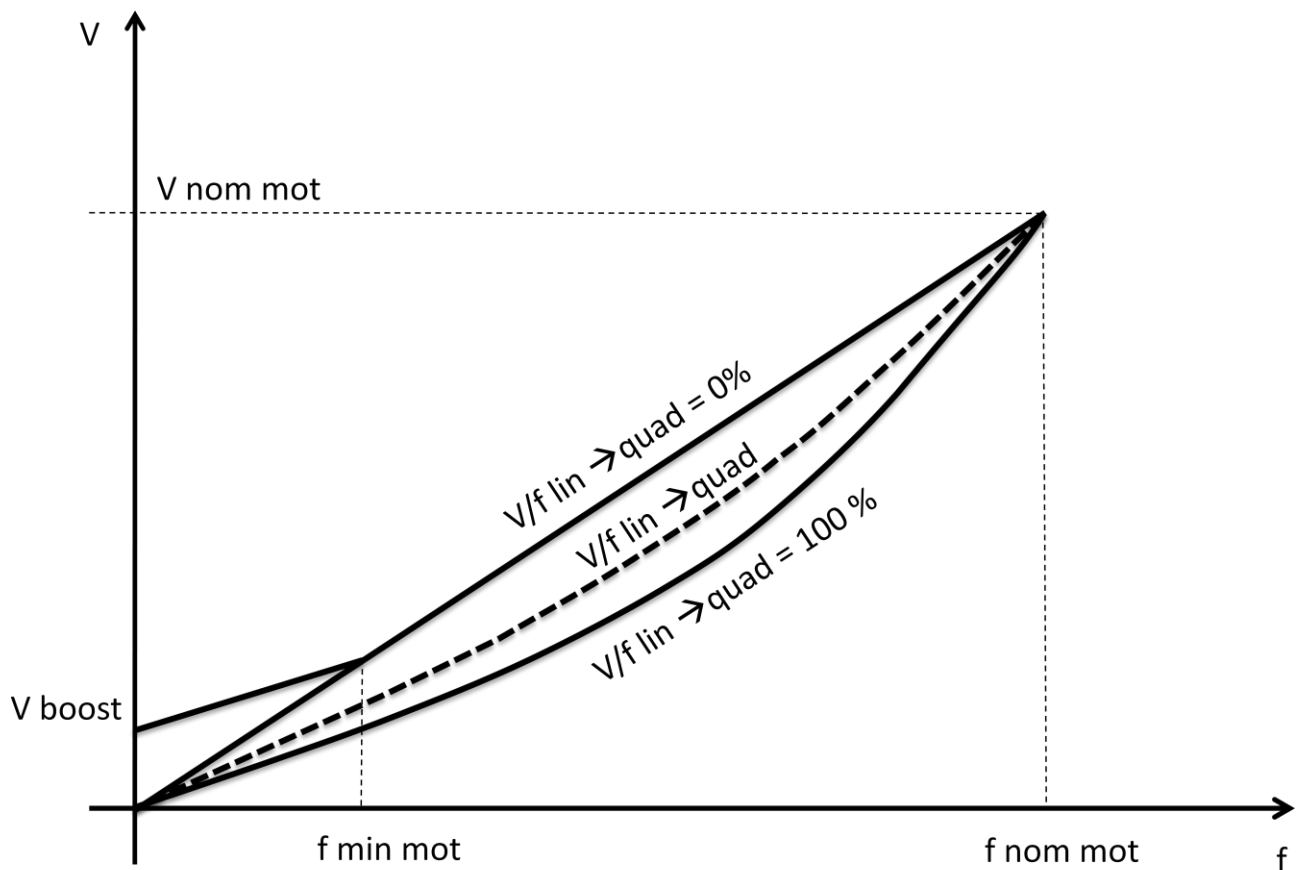

<p>Autorestart</p> <p>ON/OFF</p>	OFF	<p>If ON is selected, after a lack of voltage, Drive-Tech Solar returns to its normal status; if Drive-Tech Solar was powering the pump before the voltage drop, it resumes powering the pump automatically. <u>Warning</u>, review the advice in chapter 1.</p>
<p>Periodic autorun</p> <p>t = XX [h]</p>	0	<p>Pump periodic autorun after XX hours of inactivity. Value 0 makes function disabled. <u>Warning</u>, review the advice in chapter 1.</p>

AN1,AN2 function XXXXXX	Indipendent	Function logic for analog input AN1,AN2.
Offset input 1 x = XX.X [%]	20%	Zero correction for analog input 1 (20 mA x 20% = 4 mA).
Offset input 2 x = XX.X [%]	20%	Zero correction for analog input 2 (20 mA x 20% = 4 mA).
Offset input 3 x = XX.X [%]	20%	Zero correction for analog input 3 (20 mA x 20% = 4 mA).
Offset input 4 x = XX.X [%]	00%	Zero correction for analog input 4 (default 0-10V) (10V x 00% = 0 V).
Change PASSWORD2 ENT		Pressing ENT allows the advanced level password (2st level) (default 002) to be changed.

8. Protections and alarms

Anytime a protection occurs a blinking message is displayed together with an audible alarm; on STATUS in the initial view, the protection is displayed; by pressing the STOP button. Only from this position (STATUS) in the initial view is it possible to try to reset the alarm; if Drive-Tech Solar does not reset the alarm it is displayed again together an audible sound.

ALARM MESSAGE	ALARM DESCRIPTION	POSSIBLE SOLUTIONS
OVERCURRENT MOT.	<p>Motor overload: input current of the motor is higher than the rated motor current setting parameter.</p> <p>Motor voltage drop caused by the inverter causes the motor input current to be higher than rated. Contact motor manufacturer to check if motor is capable of accepting this current.</p>	<ul style="list-style-type: none"> • Make sure that the motor current setting parameter is higher than rated. • Check other possible causes of over current.
UNDER VOLTAGE	Supply voltage too low	Check possible causes of undervoltage.
OVER VOLTAGE	Supply voltage too high	Check possible causes of overvoltage.
OVER TEMP. INV.	Inverter over temperature	<ul style="list-style-type: none"> • Make sure than ambient temperature is less than 50 °C (104 °F). • Check if auxiliary cooling fan is working properly and if mounting space is adequate for proper cooling. • Reduce the PWM value (<i>Advance Parameter Menu</i>).
NO LOAD	No load	<ul style="list-style-type: none"> • Check if load is properly connected to the Drive-Tech Solar terminals
NO WATER (DRY RUN COSPHI)	Motor cosphi is lower than the set value of dry running cosphi	<ul style="list-style-type: none"> • Check if the pump is primed • Check the set value of dry running cosphi. Dry running cosphi is approximately 60% of the rated cosphi (at rated frequency) listed on the motor plate. <p>If pump's cosphi is lower than the set dry-running cosphi for at least 2 seconds, Drive-Tech Solar stops the pump. Drive-Tech Solar tries to run the pump every 10, 20, 40, 80, 160 minutes and then the pump is stopped.</p> <p>WARNING: if dry running protection occurs, Drive-Tech Solar will try to start the pump automatically. Be sure to cut power supply to Drive-Tech Solar before performing any maintenance.</p>
SENSOR FAULT	Sensor error	<ul style="list-style-type: none"> • Check the transducer • Check the wiring of transducer
MAX. VALUE ALARM	Measured value has reached the maximum value accepted by the system.	<ul style="list-style-type: none"> • Check possible causes of reaching max value • Check the max alarm value setting

MIN. VALUE ALARM	Measured value has reached the lowest value accepted by the system.	<ul style="list-style-type: none"> • Check possible causes reaching min value (i.e. broken pipe, open pressure relief valve, etc.) • Check the min alarm value setting.
IGBT TRIP ALARM	The current drawn by the load exceeds the capacity of DrivE-Tech Solar. DrivE-Tech Solar is still able to continue to power the load for 10 minutes with an output current of 101% of nominal and for 1 minute with an output current of 110% of nominal	<ul style="list-style-type: none"> • Increase the ramp-up time. • Make sure that the load current is at least 10% below the DrivE-Tech Solar nominal current. • Check the voltage drop along the supply cable to the motor.
NO COMMUNICATION	Communication between Master and slave(s) has been interrupted	<ul style="list-style-type: none"> • Check the wiring connections • Make sure the Master is not in the Menu level; if so, exit from the level. • In the STATUS of the slave (where the alarm is displayed) try to reset the alarm by pushing STOP button.
ADDRESS ERROR	Same address as other DrivE-Tech Solars in the group	<ul style="list-style-type: none"> • The address of each DrivE-Tech Solar needs to be different
KEYBOARD FAULT	A Button on the keyboard has been pressed for more than 150 seconds	<ul style="list-style-type: none"> • Make sure buttons are not depressed • Call service assistance
ACTIVE DIG.IN.X	Digital input X opened /closed	<ul style="list-style-type: none"> • Check the input digital configuration (Installer Parameters menu)
ALARM SLAVE XX	slave XX error detected by master	<ul style="list-style-type: none"> • check the status of the slave
	<p>If pumps cosphi is lower than the dry-running cosphi for at least 2 seconds, DrivE-Tech Solar will stop the pump. DrivE-Tech Solar will try to run the pump every 10, 20, 40, 80, 160 minutes and then the pump is stopped.</p> <p>ATTENTION: if dry-running protection occurs, DrivE-Tech Solar will try to start the pump automatically. Be sure to cut power supply before attempting maintenance</p> <p>DrivE-Tech Solar will stop the pump if the input motor current is higher than the set motor current for an extended time. By pressing the START button it is possible to run the pump again.</p> <p>DrivE-Tech Solar will stop the pump if the input voltage is higher than the set voltage for an extended time. By pressing the START button it is possible to run the pump again.</p> <p>DrivE-Tech Solar will stop the pump if the input voltage is lower than the set voltage for an extended time. By pressing the START button it is possible to run the pump again.</p>	

DICHIARAZIONE DI CONFORMITA'

Secondo:

Direttiva Macchine 2006/42/CE

DrivE-Tech Solar è un dispositivo elettronico da collegare ad altre macchine elettriche con le quali viene a formare singole unità. E' necessario, pertanto, che la messa in servizio di questa unità (corredata di tutti i suoi organi ausiliari) sia effettuata da personale qualificato.

Il prodotto è conforme alle seguenti normative:

EN 60146

EN 50178

EN 60204-1

Vertical S.r.l

Riccardo Fornasa
Director of Engineering - R&D

DECLARATION OF CONFORMITY

In according with:

Machine Directive 2006/42/EC

DrivE-Tech Solar is an electronic device to be connected to other electrical equipment with which it is to form individual units. It must, therefore, that the putting into service of this unit (with all its subsidiary equipments) to be performed by qualified personnel.

The product conforms to the following regulations:

EN 60146

EN 50178

EN 60204-1

Vertical S.r.l

Riccardo Fornasa
Director of Engineering - R&D
